

# ***New* Link Lift Watch**

Lift communicator

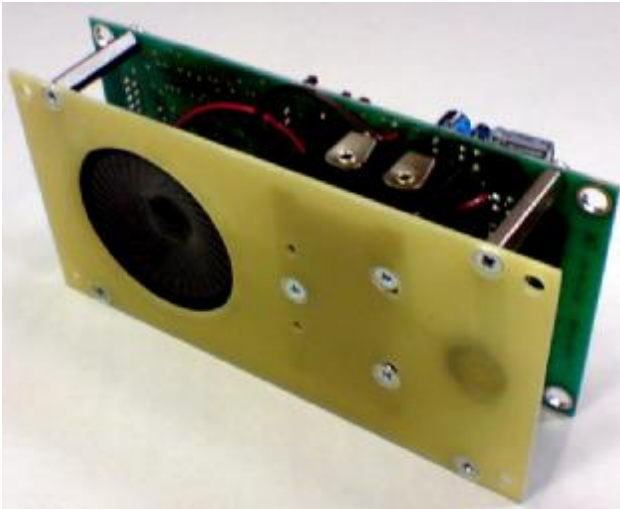

USER GUIDE



# Welcome

The Link Lift Watch is designed for emergency call from lift to first aid ( service department, police, etc...

The LLW is certified for 1 lift cabin. It is connectable to analog PSTN line or analog extension of PABX. The LLW is powered from telephone line – the features reminds hands free phone. It is completely independent on lift power supply. The signalization as same as status detection only requires connection of external power supply. All inputs even outputs are galvanically isolated from telephone line. The button as same as control („third“) wire only is connected with telephone line.

The LLW has adjustable parametres saved in internal memory. The parametres might be programmed either by phone via tone (DTMF) dial or by computer PC via configuration software. For connection the LLW to PC you have to use special cabel.

After button pressing the LLW enables to make phone call up 6 numbers max 16 digits in tone or pulse dial. It is possible also dial

“ \* ”, “ # ”, **Pauze** and **Flash** in tone dial. The button activation might be blocked by input BLOCK. As follow LLW enables to make a call in case of change the status at input INP1 (failure). The LLW also provides automatic phone call from systém time clock to confirm its functionality.

At all numbers is possible to use mode with or without confirmation.

After confirmation of phone call by called party the LLW reply by its seriál number and current call is taken as accepted. It means that LLW not dial any other number saved in memory.

The next feature is remote control of relay in connection with LLW by 2 digit code. The switching contact of relay is isolated from the outstanding components. It is very useful feature for example : LIFT RESET .



Manual version V5.5 22.5.2008

Alphatech spol. s r.o.

Jeremenkova 88

140 00 Praha 4

Tel/fax: 272103334

[www.alphatech.cz](http://www.alphatech.cz) / [info@alphatech.cz](mailto:info@alphatech.cz)

# Content

---

<b>1</b>	<b>BASIC DESCRIPTION</b> .....	<b>5</b>
1.1	FEATURES .....	5
1.2	TERMINOLOGY .....	6
1.3	WIRING CONTACTS .....	7
1.3.1	<i>Description of basic module</i> .....	7
1.3.2	<i>Setting voice communication</i> .....	9
1.3.3	<i>DTMF level setting</i> .....	10
1.3.4	<i>Telephone line connection (LINE a b)</i> .....	10
1.3.5	<i>Button and blocking connection (BTN a BLOCK)</i> .....	11
1.3.6	<i>Connection of optical signalization (YELLOW and GREEN)</i> .....	13
1.3.7	<i>Input connection- failure notification (INP1)</i> .....	14
1.3.8	<i>Connection of machine room communication (3WR)</i> .....	15
1.3.9	<i>Relay connection (12V and NC/COM/NO)</i> .....	16
1.4	LLW INSTALLATION.....	17
<b>2</b>	<b>LLW SERVICE</b> .....	<b>18</b>
2.1	THE LLW SIGNALLING TONES .....	18
2.2	CALLING FROM LLW .....	19
2.2.1	<i>Emergency call (button activation)</i> .....	19
2.2.2	<i>Calling from INP1 activation (failure)</i> .....	19
2.2.3	<i>Service calling ( from timer)</i> .....	20
2.2.4	<i>End of calling – call confirmation</i> .....	20
2.2.5	<i>Machine room connection</i> .....	21
2.2.6	<i>Incoming call</i> .....	21
<b>3</b>	<b>PARAMETRES PROGRAMMING</b> .....	<b>22</b>
3.1	PROGRAMMING BY TELEPHONE: .....	22
3.1.1	<i>Enter to programming mode</i> .....	22
3.1.2	<i>Programming of parametres</i> .....	22
3.2	PC PROGRAMMING– PROGRAMM LIFT SET .....	23
<b>4</b>	<b>PARAMETRES DESCRIPTION</b> .....	<b>24</b>
4.1	PHONE NUMBERS MEMORY .....	24
4.2	OPERATION .....	25
4.3	BASIC PARAMETRES.....	26
4.4	TIME PARAMETRES .....	28
4.5	PRESETTING AND ERASING .....	30
4.6	ENDING OF PROGRAMMING .....	30
4.7	SYSTEM SETTING .....	31
4.8	PARAMETERS OVERVIEW .....	32
<b>5</b>	<b>TECHNICAL PARAMETRES</b> .....	<b>33</b>
5.1	ELEKTRICAL PARAMETRES .....	33
<b>6</b>	<b>TABLE FOR EASY LLW PROGRAMMING</b> .....	<b>34</b>

# 1 Basic description

---

## 1.1 Features

- The unit is powered from line only (you connect line and button only!)
- The unit includes acoustic part ( micro and speaker) – compact solution! The loudness of micro as same as speaker is adjustable independently
- It is integrated anti-interference as same as protection against static electricity.
- Programming is either remotely by phone (DTMF tones) or by PC (serial port RS232 or USB with convertor to RS232)
- It includes switchable relay contact . You can control remotely by phone.  
You can use it for remote control of the lift ( RESET). The time of relay closing is adjustable from 1 to 99 seconds.
- It includes indication light (LED) – yellow, indication of dialling the number
- It includes indication light (LED)–green,indication – connection was made.
- The time of button activation is adjustable from 0,5 sec to 5 sec
- The possibility of activation via third wire from „ transfer tool“ for communication with machine room
- Security against disusing of alarm buttons (activation during failure 5-24V).
- It includes universal input which you can use for failure announcement ( doors, power supply, etc..) You can programm special phone number .
- All inputs as same as outputs are galvanically isolated – not depends on polarity. ( except button and third wire for machine room).
- Acoustic as same as optical signalling of LLW status
- The possibility to programm 6 numbers ( 16 digits – includes \*,#,Pause,Flash) with note if you want use confirmation or not .The numbers are progressively dial.
- Regular automatic control of system functionality ( automatic calling to preprogrammed numbers in set time period from 1 to 10 days)
- The possibility programm code for remote activation or unactivation of LLW

## 1.2 Terminology

It is explain here the meaning of used words in manual.

<b>Communicator LLW</b>	- it is final product designed for communication from lift cabin to service center.
<b>Emergency call</b>	- it is person calling while lift failure or other emergency situation happened. It is activates by button pushing. The call is being between lift cabin and service center.
<b>Service calling</b>	- it is calling regularly repeated. (for example every 3 days). It is automatic proving of LLW functionality. )
<b>Failure calling</b>	- it is calling caused by status change on input INP1
<b>Machine room call</b>	- it is calling between lift cabin and machine room, )
<b>Incoming call</b>	- it is calling coming from outside into LLW unit. The LLW pick up (you can programm parametres)
<b>Dial</b>	- it is kind of dial on telephone line – <b>dial</b> (DTMF) dial (dial even acknowledgement * and # , use loop interruption = Flash) or <b>pulse</b> – (dial only numeral)
<b>Telephone line</b>	- PSTN line ( <b>public line</b> ) (line coming directly from Telecommunication carrier) or <b>extension line</b> (coming from PBX)
<b>confirmation</b>	- dial of combination star * and numerals. After dialling of those characters the call is authorised and lift communicator reply by its unique serial number. (5 digits)
<b>serial number</b>	- each lift communicator LLW has unique seriál number since 00001 to 65535. This number is sending via DTMF every time when LLW receives confirmation character
<b>call connection</b>	- this status is indicated via lighting of green check – light and might be caused either by call confirmation ( dial confirmation character) or when is not present ringing tone for longer time period.

### 1.3 Wiring contacts

#### 1.3.1 Description of basic module

The LLW is compact solution of communicator, it means that contains loudspeaker, microphone, screw terminal and connector for PC connection (configuration). At picture 1,2 is drawing of LLW basic board. Functionality of connection is explain in follow chapters. On the basic board are 3 setting elements ( trimmers ) :

**MIC** – microphone volume setting

**VOL** – loudspeaker volume setting

**TRH** – setting of balance between micro and speaker

Note: Please take in mind during TRH setting that incoming direction ( speaker) and outgoing direction ( microphone) are influence each other.

We recommend to dont set high volume in the begining of micro or speaker and via **TRH** set both direction to be both in good volume quality.

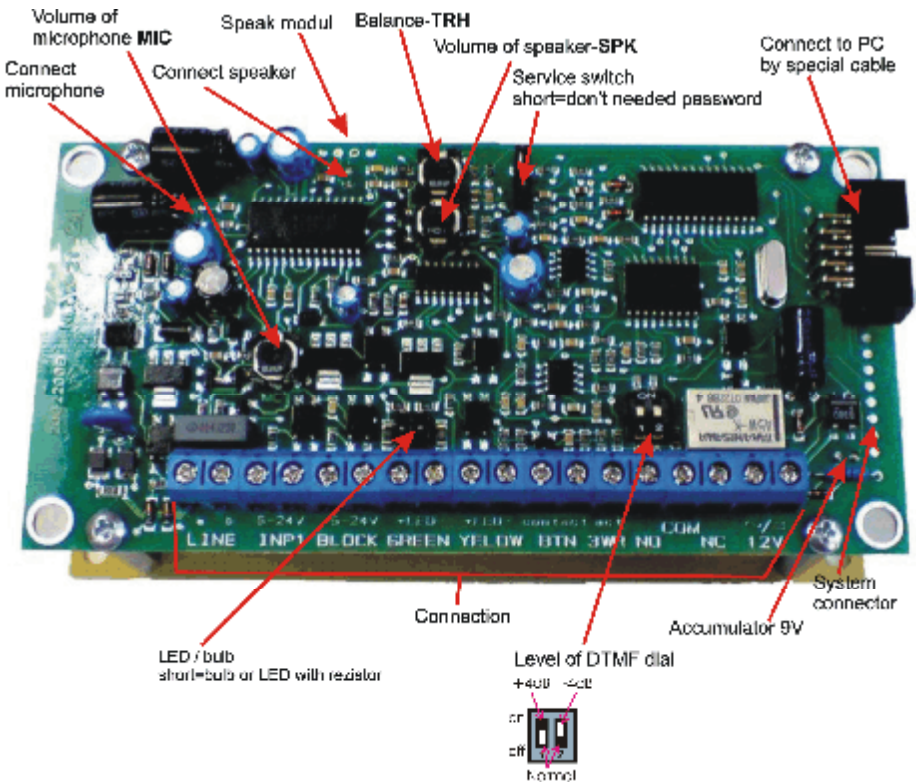

Picture 1: LLW basic board

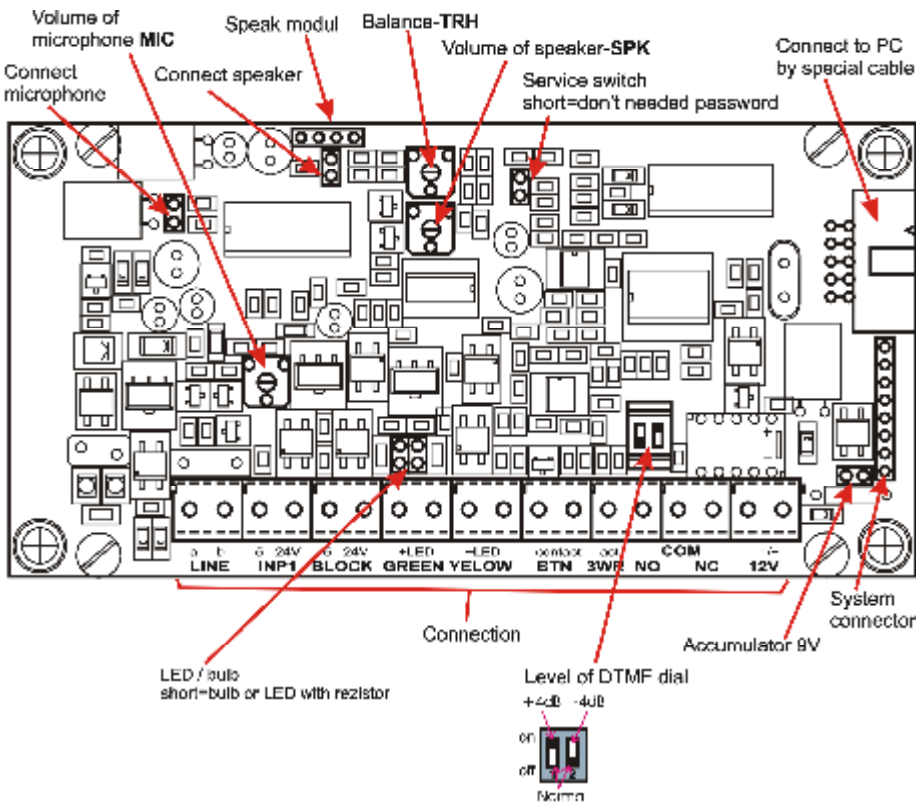

**Picture 2 LLW basic Board**

For explanation: when signal into speaker approach certain level then decreases micro volume to enter signal into speaker. At the other hand signal from microphone decreases volume of speaker. By **TRH** trimmer you are setting preferention of microphone or speaker.

Here you can see that when is set high volume of microphone (**MIC**) as same as speaker (**VOL**) then signals influence each other. The result might be that call is interrupted or one direction is silent.

The loudspeaker as same as microphone are connected by wires as you can see on picture 1,2. Caution on polarity of microphone because is powered (+ -)

The jumper marked **SERVICE** is available for automatic enter to programming mode when password is forgotten. When jumper is ON And you make incoming call on LLW then after picking up you are directly in programming mode. In programming mode you can change all parametres includes new password as well.



Two jumpers behind connector for connection LEDs determine if they will be connection indication LEDs (jumpers they are open) or indication bulbs or LEDs with resistor (jumpers they are short). These jumpers just short serial resistors. At using power supply 12V is current LED c. 10mA, at short-circuited jumpers be allowed max. current 0,5A.

The black connector on opposite side from screw terminal is designed for PC connection by special cable KAB. The cable is galvanically isolated converter of RS 232 interface (PC port COM1, COM2...) and LLW interface. Galvanical isolation is necessary because PC might be grounded and telephone line MUST NOT be grounded! When your PC is not equipped by RS 232 port but only USB then you can use converter USB-RS232 for it is in your PC creates virtual serial port (for example COM6) and this you will select in configuration software LiftSet for communication to LLW.

**1.3.2 Setting voice communication**

Position trimmers are presetting from manufacture and in majority case agree with, therefore changes setting altering only in necessary case.

Trimmer "MIC" be instrumental to setting loudness of microphone, trimmer "SPK" be instrumental to setting loudness loudspeaker. In this version is big reserve in gain, therefore isn't recommended adjust more than on half, typical is in 1/3 from minimum gain. Trimmer "TRH" be instrumental to setting levels activation of microphone, it means, so as doorphone "non whoop" owing to acoustic loop so selection, which direction has priority, whether from microphone, or into loudspeaker. Level from which volume with "switch on" direction from microphone doorphone setting trimmer „TRH". This setting interact level surrounding noise and setting gain of microphone „MIC".

Progress of setting: trimmer MIC and SPK setting in 1/4 from minimum loudness (minimum is sense turning left), trimmer TRH setting in central position. At conversation connection stillly talk and trimmer TRH turning from central value direction to the left so, till you will on the side phone (in building) hear. Gain of loudspeaker, in some case of microphone set-up according to needs.

**Picture:** Typical range and sense of rotation trimmers

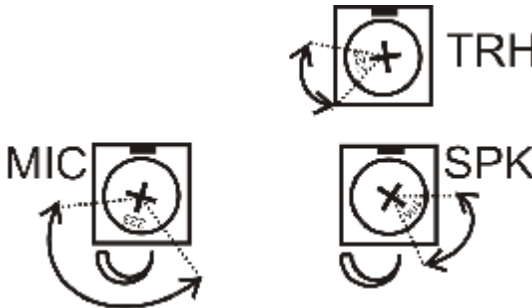

### 1.3.3 DTMF level setting

Level of DTMF dial it is possible adjust in three levels, base level is -10dBm, here it is possible restrict to -14dBm and or heighten on -6dBm. Setting is makes by DIP switch according to pictures.

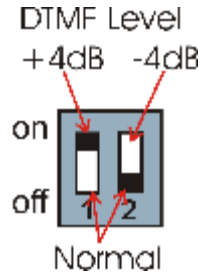

### 1.3.4 Telephone line connection (LINE a b)

The basic condition for LLW operation is telephone line connection. Telephone line is 2 wires which you connect to screw terminal up picture 3.

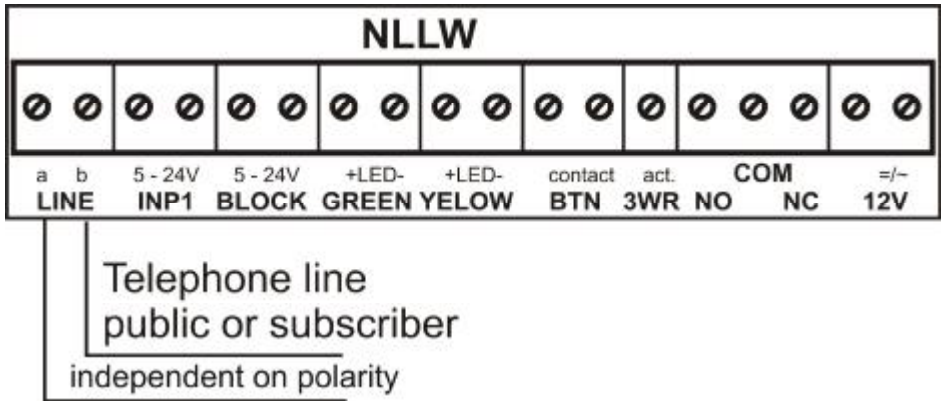

**Picture 3: Telephone line connection**

Telephone line interface has following typical parametres. The voltage in Hang up status (disconnect loop) 20-60V = (during connection not depends on polarity), when LLW pick up (active status) on telephone line is cca 7-12V, depends on line current which is in range 20-60mA. Further telephone line parametres are signalling, ringing (incoming call) is define by AC voltage from 50-90V and frequency 20 – 60Hz. To the signalling belongs even tones, have frequency 425Hz +/- 20Hz and level -10dBm (cca 0,22V) and difference lis cadency. The LLW reacts on those tones.

### 1.3.5 Button and blocking connection (BTN a BLOCK)

When telephone line is connected we need connect button only.

The button is connected to screw terminal mark BTN. Look on picture 4.

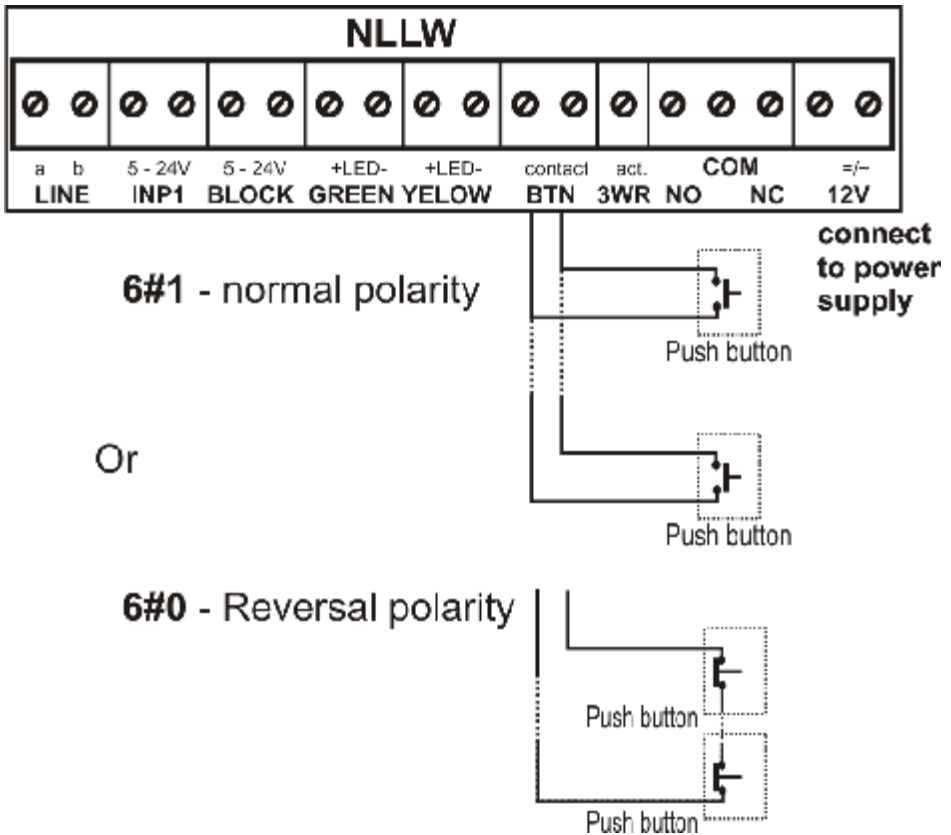

**Picture 4 : Button connection**

Button is possible connecting up to 100m and is possible connecting more buttons „switch on“ parallel or „switch off“ buttons serial. Control of type buttons use is possible programming by parameter 6# 1 or 0. System of push button is safed by 9V accumulator with charging from 12-24V power supply. Function is declared min. 7day without power supply.

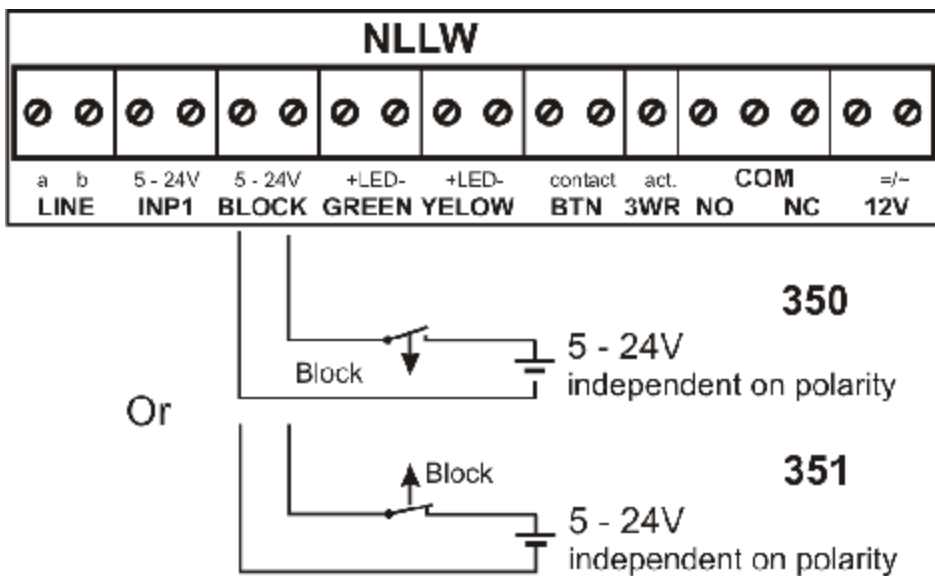

**Picture 5 : connection block of call**

The screw mark BLOCK (picture 5) is designed for blocking of button for emergency call. Input is isolated from other parts of LLW and not depends on polarity. In configuration you can select if BLOCK input is activated by leading of voltage 5-24V or by disconnection of this voltage.

### 1.3.6 Connection of optical signalization (YELLOW and GREEN)

The LLW is equipped by call status indication. It is by yellow and green indicator. The switcher outputs for those indicators are isolated from other components and each from other as well. The switchers are made until current 0,5A and voltage 50V. On Picture 6 you can see examples of lamp indicator connection (power consumption should not be higher than 5W) – jumpers is short or LED indicator connection – jumpers is open (internal add serial resistor).

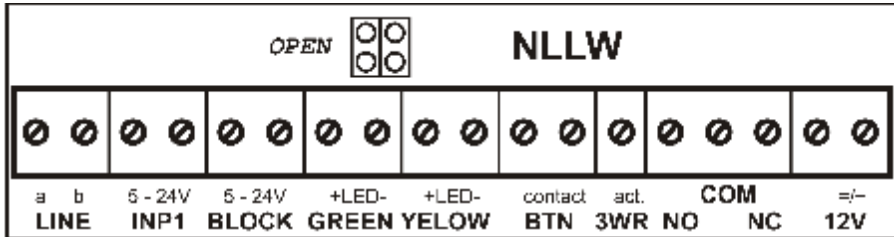

Only LEDs  
current  
cca 10mA



connect  
to power  
supply

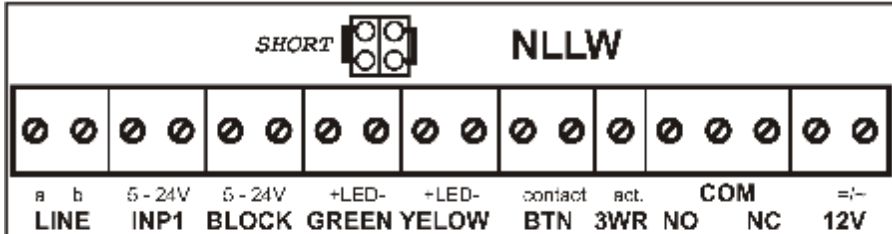

LEDs with  
resistor  
or bulb  
current  
max 500mA

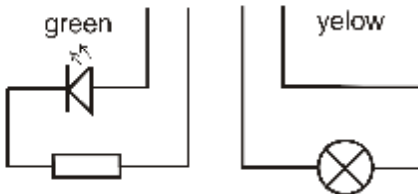

connect  
to power  
supply

Picture 6: Indicator connection

### 1.3.7 Input connection- failure notification (INP1)

On screw INP1 is possible leads voltage 5-24V for activation failure calling as you can see on picture 7.

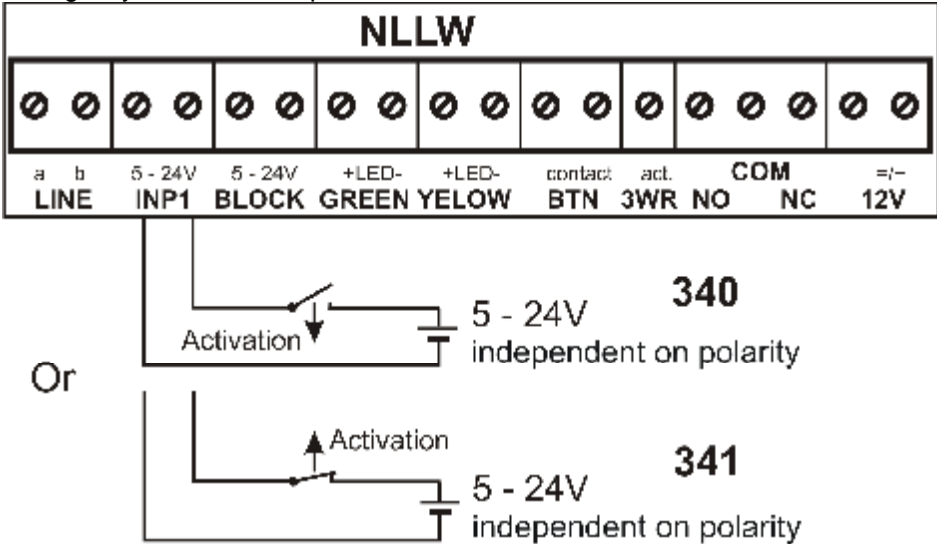

**Picture 7: Input connection for failure calling**

Is possible to programm if input should be activated by connection or disconnection of voltage on this screw. As next parameter you programm the length of this voltage change before failure calling is activated.

### 1.3.8 Connection of machine room communication (3WR)

When use in machine room modul PREPOJ you can see on picture 8 its connection. From machine room to lift cabin must lead 3 wires.

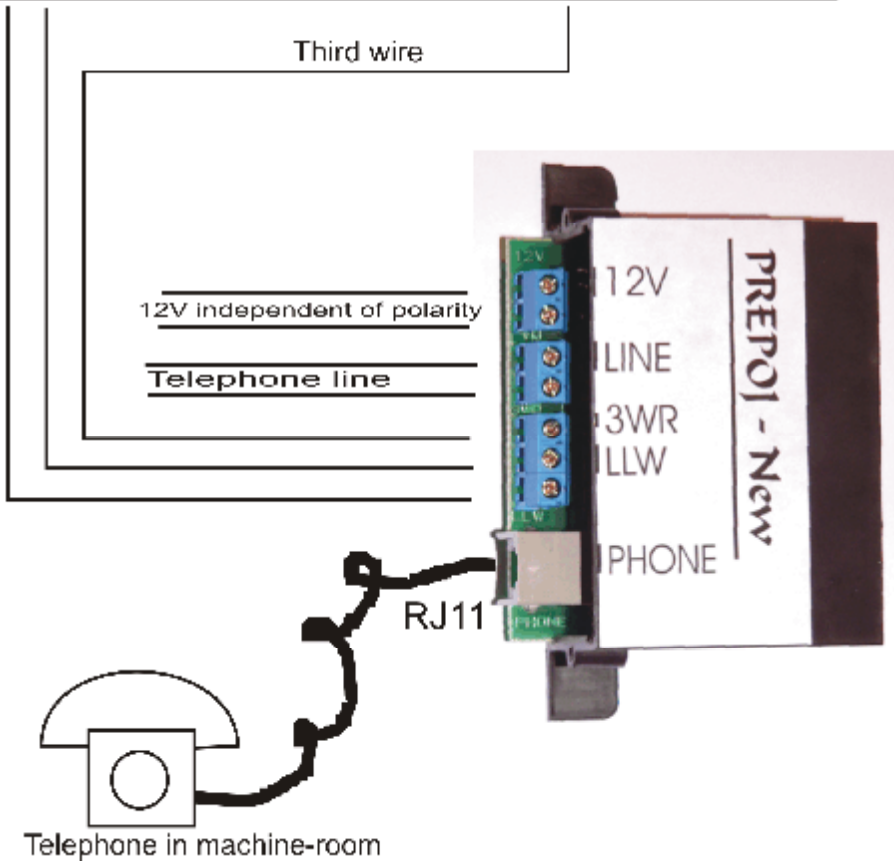
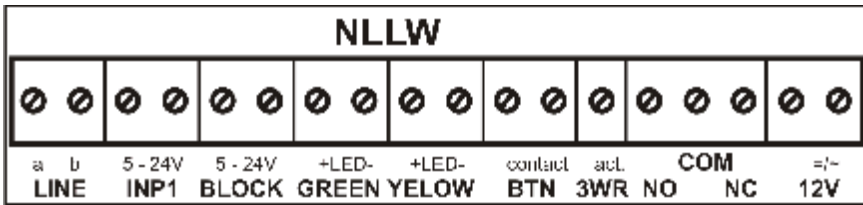

**Picture 8: Connection of machine room communication**

### 1.3.9 Relay connection (12V and NC/COM/NO)

The last feature of LLW is remote control of switchable isolated contact (relay). You can use it for remote control ( RESET of the lift), control of further lift systems, etc... Description is on picture 9.

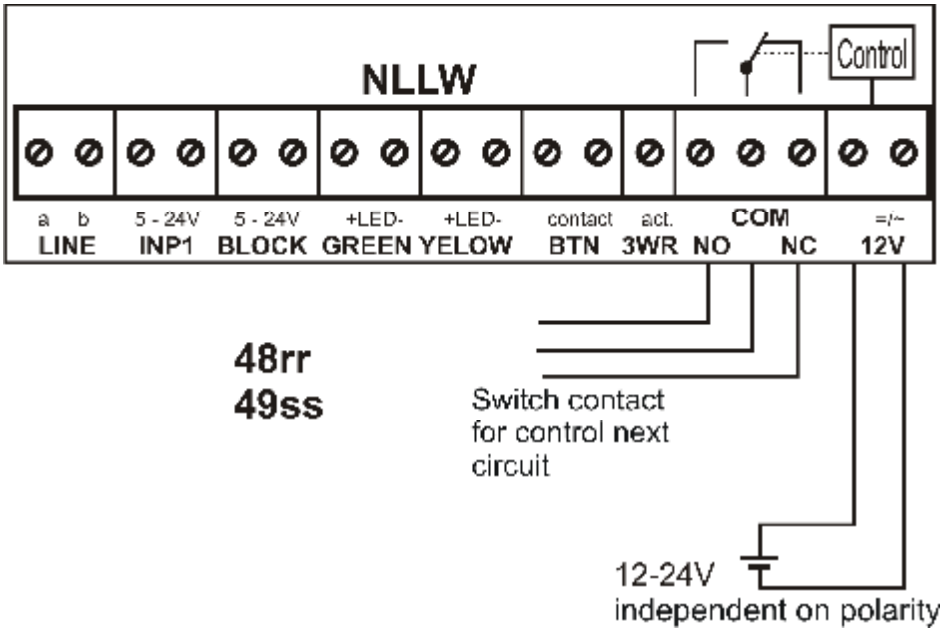

**Picture 9: Relay connection**

Screw 12V is necessary for relay powering because telephone line has not enough power. Screw 12V is isolated from other components and not depends on polarity. Screw marks COM is share output of switchable contact. Screw marks NO ( normally open) the contact in stand by is OFF and screw marks NC (normally close) the contact in stand by is ON. In configuration you can programm code and time for relay switching.

Screw 12V is necessary for LEDs and for correct function circuit for push button(s) and charge backup battery 9V for push button(s).



## 1.4 LLW Installation

The compact solution of LLW enables easy installation into lift cabin panel. Dimension and installation holes are described on picture 10.

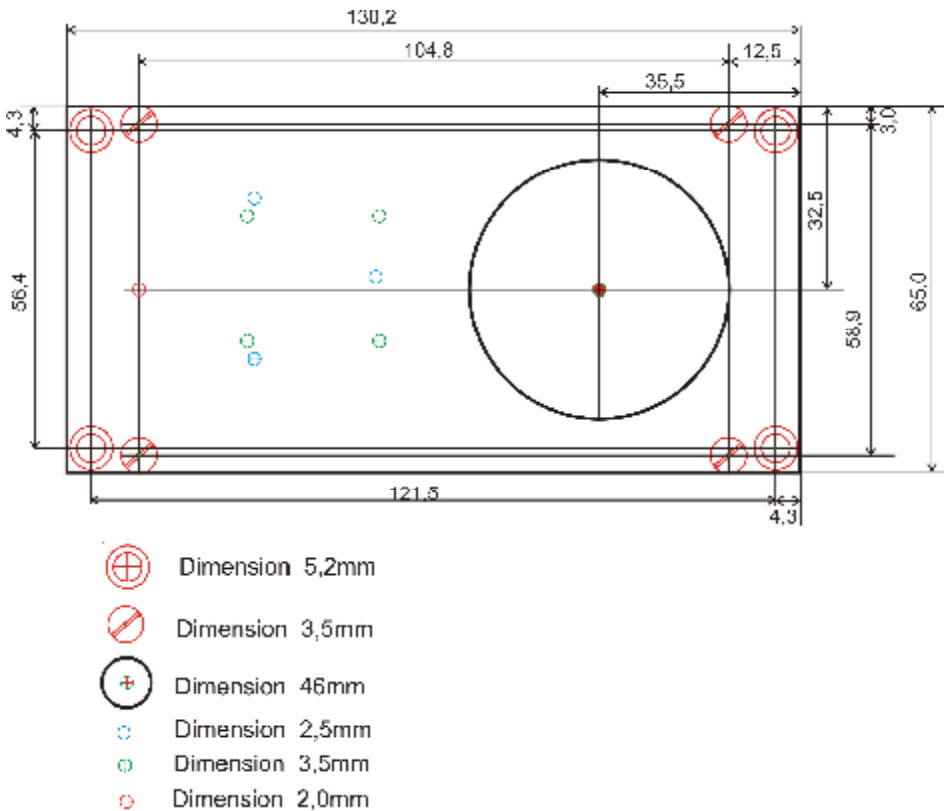

**Picture 10: LLW dimension**

The lift cabin panel should be equipped by acoustic holes in microphone as same as speaker part. It should be also provides by 4 screws M4 for fixing the LLW unit to the panel. The proper mechanical installation essentially influence acoustic parametres of the unit. Particularly microphone and speaker should be fixed tightly to acoustic holes in panel.

## 2 LLW service

### 2.1 The LLW signalling tones

The LLW signalling acoustically stages which can happen during operation. Further signalling is by Green and Yellow indicator connected in lift cabin. Acoustic samples of signalling tones you can check in configuration sw LiftSet.

Stage	Tones	frequency	Indicators
Line pick up		425-850-1275	Yellow lighting
Line hang up		1275-850-425	Light off
Notification after calling		425-850-1275	Green lighting
Command confirmation from phone		425	
Dial	DTMF/Pulse		Light off
Call			lighting x
Notification of call ending		1275	lighting x
Enter to programming mode from phone		850	Yellow lighting
Programming from phone		mod. 850	Yellow lighting
Parameter confirmation			
Enter to programming from PC		850	Sequentially flashing
Programming from PC			Sequentially flashing
Connection to telephone line (Reset)		1275-850-1275	Both flash
ERROR		425....	
Empty memory (not programmed number)		850-1275-1700...	
Calling from input INP1 (failure)		Mod. 850	Lighting off
Calling from system timer		Mod. 850	Lighting off

*lighting x – green / yellow – up stage (confirmed = green)*

**Table 1 : Signalling used in LLW**

## 2.2 Calling from LLW

The functionality of LLW is influenced by connection of further lift components (failure notification, relay,...) as same as by setting of LLW parametres (via. chapter 4 – P / page24).

### 2.2.1 Emergency call (*button activation*)

The emergency call is basic and most important feature of LLW. It is activated by button pressing (screw BTN). To provide correct functionality you must keep 2 conditions:

**First condition** is that , button blocking is not active. Please note that blocking might be either by leading voltage 5-24V or by disconnection this voltage.

**Second condition** is that button you must hold enough time. It is adjustable from 0,5 sec to 5 sec.

Button pressing has priority before other calls (service, failure even incoming). If is being a call ( not emergency) the call is stoped and starts emergency call procedure.

During emergency call is active both way voice communication. During establishing call is lighting yellow indicator . After call connection – call confirmation – green indicator light up.

Emergency call dial progressively stored numbers (1÷6 position). It starts from position 1 up to position which is not programmed. It means when you programm numbers to all 6 position then progressively dial all 6 numbers. When you erase number on position 3 then dial numbers on position 1 and 2 and returns back to position 1. You can also programm how many times the round (programmed numbers on position 1-6 should be repeated ( 1 to 5 times). While is emergency call the button does not react on other pressing and even more any other stage might not break emergency call procedure.

The machine room call only can break emergency call (chapter 2.2.5 page.21). The last point of emergency call is call confirmation . At every emergency number ( position 1-6) you can select confirmation or not. (chapter 2.2.4 – page.20.). Dialling is stoped after call connection.

### 2.2.2 Calling from *INP1 activation (failure)*

Calling from activated input INP1 is named failure calling. The LLW enables to make notification about lift failure for service department. The call is activated by voltage change ( 5-24V ON/OFF) on input INP1. It is adjustable in setting. As follow you can select time how long must be change on input INP1 to start failure calling.

Failure calling has own number which might be of course the same as emergency or service call number. You can also select if will be dialling only this number or all round of emergency numbers ( then you have max 7 numbers) .

Failure calling is not repeated. It means that all numbers are calling only once And then LLW hang up. Further round might be activated only by new change on input INP1. The voltage must returns back to stand by mode. The change on input INP1 must happen again. During failure calling are all other features available.

During failure calling is not lighting any indicator. It is not voice communication. The call is generating beeps – via. Table 1 page. 18.

### **2.2.3 Service calling ( from timer)**

Service calling is optional parameter. You alsé define if this parameter is activated since first connection of LLW to telephone line.This service calling is adjustable from 1 to 9 day period, for example 3 means that LLW is make automatically every 3th day a call to preprogrammed number. (test of LLW functionality).

For service calling you programm special number which might be of course the same as emergency or failure calling number. You can also select if will be dialling only this number or all round of emergency numbers ( then you have max 7 numbers) .

The service calling is repeated in period 0-9 min ( programmable) until succesfull call ( confirmation). The repeated time between calls is programmable because to service department can call more LLW. To avoid of problem that service department line is busy you can programm different time period for service calling up installation place.

During failure calling is not lighting any indicator. It is not voice communication. The call is generating beeps – via. Table 1 page. 18.

### **2.2.4 End of calling – call confirmation**

The LLW enables to programm at every number if will be confirm or not. Every call needs authorisation if it was succesfull or not. Therefore analog line doesnt support any kind of authorisation (signalling) we can define success of call by 2 ways. The LLW needs this info to not dial further numbers.

First way (**no confirmation**) is detection that call was succesfull on the base control ringing tone (CRT). It is tone which we are hearing in handset when make call to other subscriber. Thed LLW detects this tone And when is missing for certain time then evaluate the call was succesfull (Green indicator light up and yellow light down). The time which define undetection of CRT ( called part picks up) is adjustable because each type of PBX can be different. Usually should be 5 seconds as the best. At this call authorisation stays possibility confirm the call by dial confirmation characters (\*xxxxxx, where xxxxxx is 2-6 numerals). After dialling of confirmation characters LLW reply by its serial number (DTMF tones).

Second way (**with confirmation**) is detection that call was succesfull only by dial confirmation characters (\*xxxxxx, where xxxxxx is 2-6 numerals). This way is most reliable but requires trained people in service department

(they must be able insert confirmation characters when call is pick up), or at service department must be used evaluation software.

After dialling of confirmation characters the LLW reply by its unique seriál number. By this way is detected where from is coming a call even when more LLW is installed behind PBX. In this case is not possible detect it by CLIP because all LLW have the same CLIP due the same telephone line use for outgoing calls.

### **2.2.5 Machine room connection**

Connection between machine room and LLW is special case which has absolut priority. The reason is that during machine room communication is disconnected telephone line. The LLW accept machine room call as incoming , it means you can programm the unit , control relay,.. The call is not time limited as same as not possible hang up.

Possibility to make machine room connection is only when you use option box named „PREPOJ“ and via connection of third wire (telephone line has 2 wires And third is for LLW controlling). Wires connection is displayed on picture 8, page 15. The call is activated by picking up of phone. The LLW picks up immediatelly (is active). This status is indicated by both indicators ( green and yellow) light up. You can make voice communication. The call duration is until hang up phone in machine room.

### **2.2.6 Incoming call**

Incoming call is coming from outside to LLW. After extension dialling or land line number where is LLW connected the LLW is ringing and after preprogrammed number of rings (parameter 51) the LLW picks up And you can speak to lift cabin.

Exceptional is first 10sec, where is additionally possible insert "# and service password" (*parameter 44*), to enter programming mode.

When jumper "SERVIS" on LLW basic board is closed you are automatically going to programming mode when call is picks up. ( without service password). It is usefull when you forget service password and by this way you can programm the new one. Do not forget disconnect jumper after programming . Jumper is on the basic board (picture 1 page 7).

Incoming call is detected by green indicator. It is possible control relay. It is possible voice communication. After dialling of confirmation characters the LLW returns seriál number. The incoming call is only the way how programm the LLW by telephone (tone dial DTMF).

## 3 Parametres programming

---

### 3.1 Programming by telephone:

#### 3.1.1 Enter to programming mode

The LLW will be set to programming mode in two ways:

1. **by password** – only incoming call! – answer the telephone and dial a number, where the LLW is connected (*either extension number, if connected to PBX or number of state line to object, where the LLW is placed and let you put through to PBX directly connected with LLW*). The LLW will answer (you hear tone for answering – see Table 1 page14) up to 10 sec dial **#xxxx**, where xxxx is the service number for entry to programming and if O.K., the registration tone to programming will sound and afterwards the programming tone is heard (see Table 1 page19). Default settings is password xxxx=0000
2. **by "SERVICE" jumper** – only incoming call! – you will realize the connection with LLW in the same way as in art. 1, but when the SERVICE jumper is connected, then the LLW after answering directly comes to programming mode – you hear tone for answering, registration tone to programming and afterwards the programming tone is heard. (see Table 1 page19).

#### 3.1.2 Programming of parametres

The initial state for programming is signaled by programming tone and the guard will come back to this state always after time expiration (5 seconds) even you started to program anything.

When programming two types of parameters will occur. Partly they are parameters with **fixed length** – the majority of them they are, then the programming is affirmed and the parameter is always recorded immediately after mandatory length fulfillment by acknowledge tone and partly the parameters **with variable length** (*parameter 1,21,22,45*), followed with **confirmation** and the recording of the parameter after inactivity period expires (5 sec). The only case with immediate recording of parameters is the fulfillment of max. number of recorded signs (numbers) – by parameters 1,21 and 22 it is 16, by parameter 45 it is 6.

If during programming you enter number (sign) not allowable by its extent then the LLW immediately emits an **error tone**, the parameter will not be recorded nor changed, the LLW will come to initial state and it is possible to repeat the parameter setting or program another parameter.

The LLW stays inactive in programming mode for 34 seconds, then he will automatically hang up. By every dialing of DTMF tone this period is set up repeatedly. The selection of parameter 9 can also end the programming mode.

**Note 1.** *if you wish to keep the connection (extend the 34 seconds period) than the customer will think over the other setting, so pressing e.g.. 6, 7, 0, \* or # form time to time will be sufficient and the guard immediately responds by error tone, but he will extend the period to hanging up..*

### **3.2 PC programming– programm Lift SET**

For setting of LLW by PC you need special cabel KAB ( RS 232 port) and Programm Lift SET. The LLW must be connected to telephone line – powering.

Procedure:

- Connect the LLW to the line
- Connect the LLW with PC by KAB cable (if PC serial port absent, the USB-COM reduction is to be used). The LLW will answer and LED light on the front panel will light.
- Run the Lift SET program – the LLW will report the his conversion to PC programming mode (viz.table 1 page14). After Liftset program being run the LLW is in this mode – this status is indicated by LED light on front panel by 1 second flashing. By loss of connection it is necessary to disconnect the cable from LLW connect it again – the LLW will answer and if Liftset program runs he will report his conversion to programming mode.

## 4 Parametres description

### 4.1 Phone numbers memory

#### Emergency numbers (button activation)

Parameter	Value	Note	default
1	pt nn...	number nn in order p with confirmation t	-

**p** – Memory order of number, programm [1-6] digits only

**t** – call confirmation, programm [0-1] only, 0-confirmation OFF

**nn** – telephone number up 16 digits. To programm other characters look on table.

Basic setting as same as examples setting not change or erase those saved numbers.

note	dial
0 - 9	0 – 9
#	#
*	* *
Flash	* #
Pause	* 0

#### Service number (system timer activation)

Parameter	Value	Note	Default
21	t nn...	Number nn in order p with confirmation t	-

**t** – call confirmation, programm [0-1] only, 0-confirmation OFF

**nn** – telephone number up 16 digits. To programm other characters look on table.

Basic setting as same as examples setting not change or erase those saved numbers.

note	dial
0 - 9	0 – 9
#	#
*	* *
Flash	* #
Pause	* 0

#### Failure number (input INP1 activation)

Parameter	Value	Note	Default
22	t nn...	Number nn in order p with confirmation t	-

**t** – call confirmation, programm [0-1] only, 0-confirmation OFF

**nn** – telephone number up 16 digits. To programm other characters look on table.

Basic setting as same as examples setting not change or erase those saved numbers.

note	dial
0 - 9	0 – 9
#	#
*	* *
Flash	* #
Pause	* 0



## 4.2 Operation

Parameter	Value	Note	Default
31	a	Service calling is in status ON / OFF a	0

- a**
- **0** service calling OFF
  - **1** service calling ON after time set in parameter **56**
  - **2** service calling ON after time set in parameter **56** and moreover is activated during first telephone line connection
- service calling is activated after time set in parameter **56** and is repeated after time period set in parameter **36**

Parameter	Value	Note	Default
32	h	For service calling are used also emergency numbers	0

- h**
- **0** emergency numbers are not used. It is calling only number programmed in parameter 21
  - **1** emergency numbers are used. It is calling numbers programmed in parameter 21 and 1

List of corresponding parameters: **1 21 31 56 36**

Parameter	Value	Note	Default
33	i	For failure calling are used also emergency numbers	0

- i**
- **0** emergency numbers are not used. It is calling only number programmed in parameter 22
  - **1** emergency numbers are used. It is calling numbers programmed in parameter 22 and 1

List of corresponding parameters: **1 22 34 38**

Parameter	Value	Note	Default
34	z	Activation of failure calling on input INP1	0

- z**
- **0** failure calling is activated **by voltage connection** 5-24V
  - **1** failure calling is activated **by voltage disconnection** 5-24V

List of corresponding parameters: **1 21 33 38**

Parameter	Value	Note	Default
35	b	Button blocking - input BLOCK	0

- b**
- **0** emergency call is blocking **by voltage connection** 5-24V
  - **1** emergency call is blocking **by voltage disconnection** 5-24V

List of corresponding parametres: **1 53**

Parameter	Value	Note	Default
<b>36</b>	<b>c</b>	Time of service call repeating	<b>5</b>

**c** – **0 ÷ 9** – unsuccessfull service call is repeated after time 0 ÷ 9 minutes. This time is adjustable to repeated service call from more LLW doesnt come in same time.

List of corresponding parametres: **31 56**

Parameter	Value	Note	Default
<b>37</b>	<b>d</b>	Number of emergency call sequence repetition	<b>1</b>

**d** – **1 ÷ 5** times is repeated dial of emergency numbers (button pressing). Emergency numbers are dialled from first position until empty or 6th position. This is 1 sequence. It might be repeated max 5 times.

List of corresponding parametres: **1**

Parameter	Value	Note	Default
<b>38</b>	<b>e</b>	Time of failure duration before failure calling is activated	<b>1</b>

**e** – **0 ÷ 9** is time [sec] of permanent failure duration on input INP1 to be activated failure calling

List of corresponding parametres: **22 33 34**

### 4.3 Basic parametres

Parameter	Value	Note	Default
<b>41</b>	<b>v</b>	Dial type <b>v</b> – tone / pulse	<b>0</b>

**v** – dial type  
**v=0** DTMF tone dial  
**v=1** pulse dial

List of corresponding parametres **1 21 22**

Parameter	Value	Note	Default
<b>42</b>	<b>z</b>	Character for prolonging of call	<b>*</b>

**z** – character for prolonging of call \* or # (10sec before end of call the LLW send notification tone – you can prolong the call by pressing character

List of corresponding parametres: **52**

Parameter	Value	Note	Default
43	bb	Code for hanging the LLW from phone	44

**bb** – code for hanging the LLW from phone [2 digits]

List of corresponding parametres: **52**

Parameter	Value	Note	Default
44	xxxx	Service password ( during dial in advance #)	0000

**xxxx** – service password for enter to programming mode

List of corresponding parametres: **8# 84**

Parameter	Value	Note	Default
45	yyyyyy	Confirmation character (during dial in advance *)	66

**yyyyyy** – confirmation character is numerals combination - from 2 to 6 numerals

List of corresponding parametres: **1 21 22**

Parameter	Value	Note	Default
46	c	Time waiting for confirmation $c \times 5$ [sec]	5

**c** –  $5 \div 50$  sec (0 = 50 sec) is time which after number dialling the LLW waiting for call confirmation. It is calculate that value c ( number dial from phone during programming) is  $x \cdot 5$ .

List of corresponding parametres: **1 21 22 45**

Parameter	Value	Note	Default
47	e	Time without ringing tone – call detection	5

**e** –  $1 \div 10$  sec (0 = 10 sec) is time for which is not detected ringing tone after dialling of number. If is set at number dial without confirmation then is set that call started.

List of corresponding parametres: **1 21 22**

Parameter	Value	Note	Default
48	rr	Code rr for switching relay from phone	55

**rr** - code for switching relay from phone (2 digits)

List of corresponding parametres: **49**

Parameter	Value	Note	Default
49	ss	Time of relay switching <b>ss</b> [sec]	05

**ss** - time [sec] of relay closing after dialling of code from phone (2 digits)

List of corresponding parametres: **48**

#### 4.4 Time parametres

Parameter	Value	Note	Default
51	q	Number of rings before LLW picks up the call	2

**q** – number of incoming call rings. The LLW picks up always between rings. It is 2 seconds after detection **q** – th rings. The number is adjustable from 1 to 9.

List of corresponding parametres: **44**

Parameter	Value	Note	Default
52	d	Max call duration	2

**d** – max time when LLW is OFF HOOK. This time is possible change during a call by dial appropriate character from phone (\* or #). Programming of time is up table.

List of corresponding parametres: **42**

Dial	time
0	0,5 min
1 ÷ 9	1÷9 min
*	15 min
#	30 min

Parameter	Value	Note	Default
53	w	Time of button pressing (holding) for emergency call activation	2

**w** – min time for which must be button hold pressed to start emergency call procedure. The calculation is  $(w \times 0,5) + 0,5$  sec, it means 0=0,5sec, 3=2sec.... 9=5sec

List of corresponding parametres: **1**

Parameter	Value	Note	Default
54	z	Hanging up time during redial	2

**z** – is time [sec] for which the LLW hangs up before dialling next number – not confirmed call or called part is busy , etc... [range 1-5 sec]

List of corresponding parametres: **8# 85**

Parameter	Value	Note	Default
55	y	Time before number dialing	1

**y** – is time [sec] after picks up the line and dialling the number [range 1-5 sec]. This time is different for each PBX type but usually all PBXs works with time up 2 seconds.

List of corresponding parametres: **8# 85**

Parameter	Value	Note	Default
56	h	Number of days after which is perform service call	3

**h** – [1 ÷ 9 days] after programmed time in parameter 21 eventually parameter 1 the LLW call to service department to notify its full operation (functionality). The time from last call is display in Lift set programm.

List of corresponding parametres: **31 32 36 45**

Parameter	Value	Note	Default
57	t	The time of DTMF dial (tone) duration	5 (100ms)
58	m	The time of space between DTMF tones	5 (100ms)
59	f	The time of Flash	1 (100ms)
50	p	The time of pause /internumeral space	8 (800ms)

**t** – the time of tone duration is calculate:

$$(\text{insert number} + 5) \times 10 = \text{tone duration time [ms]}$$

[range 1-0 , it is 60-150ms]

**m** – the time of space between tones is calculate:

$$(\text{insert number} + 5) \times 10 = \text{space duration time [ms]}$$

[range 1-0, it is 60-150ms]

**f** – the time of Flash is calculate:

$$\text{insert number} \times 100 = \text{Flash duration time [ms]}$$

[range 1-6, it is 100-600ms]

**p** – the time of pause is calculate:

$$\text{insert number} \times 100 = \text{pause duration time [ms]}$$

[range 5-0 , it is 500-1000ms]

– time **p** is simultaneously time of internumeral space in pulse dialling

List of corresponding parametres: **1 21 22 serial number sending**

## 4.5 Presetting and erasing

Parameter	Value	Note	Default
8#	#	default	perform

This setting not influence parametres 1 and 2 (numbers saved in memory)

Parameter	Value	Note	Default
81		Erase all phone numbers	1.. and 2..only
83		Default setting for parametres 3x only	3..only
84		Default setting for parametres 4x only	4.. only
85		Default setting for parametres 5x only	5.. only

Parameter 81 perform erasing of all numbers saved in memories of emergency, service and failure call.

Parametres 83 – 85 perform selected default for parametres 3.. – 5.. only

**CAUTION !!!** erasing is unreturnable !!! It is necessary programm again.

## 4.6 Ending of programming

Parameter	Value	Note	Default	Ex. 1	Ex. 2
9		E N D			

After 9 dial into programing tone the LLW hangs up. When programming is via PREPOJ box from machine room it is not hangs but returns back to standard communication lift cabin-machine room.

## 4.7 System setting

Parameter	Value	Note	Default	Ex. 1	Ex. 2
6	z	switch off acoustic signalling	3	3	3

By default is status of communicator acoustic signalling, it however can cause false dial at cheap exchange. Parameter „z" it is possible this signalling switch off. Values are:

- z=0 – all signalling is switched off
- z=1 – only tones pick up and hang-up
- z=2 – only other tones (except pick up and hang-up)
- z=3 – all tones they are switched on

Parameter	Value	Note	Default	Ex. 1	Ex. 2
6#	p	polarity input buton of emergency call	1	1	1

Normal polarity of emergency buton is switch on by pushing buton, opposite polarity is switch off by pushing button.

- p=1 – normal polarity - activate by switch on
- p=0 – opposite polarity - activate by switch off



**Attention:** for correct function of push buton is necessary connect power supply 12V

## 4.8 Parameters overview

Parameter	Value	Note	Default
1	<b>pt nn...</b>	Number <b>nn</b> in order <b>p</b> with confirmation <b>t</b>	-
21	<b>t nn...</b>	Number <b>nn</b> in order <b>p</b> with confirmation <b>t</b>	-
22	<b>t nn...</b>	Number <b>nn</b> in order <b>p</b> with confirmation <b>t</b>	-
31	<b>a</b>	Service calling is in status ON /OFF	0
32	<b>h</b>	For service calling are used also emergency numbers	0
33	<b>i</b>	For failure calling are used also emergency numbers	0
34	<b>z</b>	Activation of failure calling at input INP1	0
35	<b>b</b>	Blocking of button by input BLOCK	0
36	<b>c</b>	Time of service call repeating	5
37	<b>d</b>	Number of repeating the emergency call sequences	1
38	<b>e</b>	The failure time duration before activation of failure calling	1
41	<b>v</b>	Dial type <b>v</b> – tone/ pulse	0
42	<b>z</b>	Character to prolong a call	*
43	<b>bb</b>	Code for LLW hanging up from phone	44
44	<b>xxxx</b>	Service password (during dial in advance #)	0000
45	<b>yyyyyy</b>	Confirmation character (during dial in advance*)	66
46	<b>c</b>	Time waiting for confirmation <b>cx5</b> [sec]	5
47	<b>e</b>	Time without ringintg tone – call detection	5
48	<b>rr</b>	Code <b>rr</b> for relay closing from phone	55
49	<b>ss</b>	Time of relay closing <b>ss</b> [sec]	05
51	<b>q</b>	Number of rings before LLW picks up incoming call	2
52	<b>d</b>	Max call duration	2
53	<b>w</b>	Time button pressing (holding) for activation emergency call procedure	1
54	<b>z</b>	Hanging up time when is redial	2
55	<b>y</b>	Time before start dialling	1



56	h	Number of days,after this time make service call	3
57	t	Tone (DTMF) duration time of tone dial	5 (100ms)
58	m	The time of space between DTMF tones	5 (100ms)
59	f	The time of Flash	1 (100ms)
50	p	The time of pause /internumeral space	8 (800ms)
8#	#	Default	perform
81		Erase all phone numbers	1.. and 2.. only
83		Default setting for parametres 3x only	3..only
84		Default setting for parametres 4x only	4..only
85		Default setting for parametres 5x only	5.. only
9		E N D	

## 5 Technical parametres

### 5.1 Elektrical parametres

Parameter	Value	Conditions
Min line current	18mA	Line OFF HOOK
Min line voltage	18V	Line ON HOOK
Line voltage when is LLW OFF HOOK (VA diagram)	< 8V < 12V	I = 20mA I = 60 mA
Ground in ON HOOK status	< 50uA	U = 60V
Impedance line ending	130R + 820R paral. 220n	Line OFF HOOK
Frequency range	300Hz – 3400 Hz	20 - 60mA
Ringing impedance	> 2Kohm	25 – 60 Hz
Sensitivity of ringing detection	min. 10 – 25 V	
Pulse dial	40 / 60 ms	
Tone dial level	-10 a -8 dBm	20 – 60 mA
Tone dial sensitivity	40 dB	20 – 60 mA
Tone detection sensitivity	30 dB	20 – 60 mA
Powering for relay control	12Vss ± 2V , 10-12Vst ± 2V	
Max consumption for relay powering	50mA	12Vss

Max. voltage of relay contact	48V	when I < 1A
Max. current of relay contact	2A	when U < 30 V
Operation temperature	- 20 to + 50 st	

## 6 Table for easy LLW programming

To empty parts of table write values of parametres which you want to be programmed. Moreover the values stays in manual for future changes.

Note		Programming procedure		digits
description	detail	par.	Write values	
Emergency number position <b>1</b>	Confirm 1/0	<b>11</b>		16
Emergency number position <b>2</b>	Confirm 1/0	<b>12</b>		16
Emergency number position <b>3</b>	Confirm 1/0	<b>13</b>		16
Emergency number position <b>4</b>	Confirm 1/0	<b>14</b>		16
Emergency number position <b>5</b>	Confirm 1/0	<b>15</b>		16
Emergency number position <b>6</b>	Confirm 1/0	<b>16</b>		16
Service call number	Confirm 1/0	<b>21</b>		16
Failure call number	Confirm 1/0	<b>22</b>		16
Service call switch ON	0 / 1 / 2	<b>31</b>		1
For service call use emergency numbers	1 / 0	<b>32</b>		1
For failure call use emergency numbers	1 / 0	<b>33</b>		1
Activation of failure call - INP1	1 / 0	<b>34</b>		1
Blocking of button activation	1 / 0	<b>35</b>		1
Time of service call repeating	1 – 0	<b>36</b>		1
Number of emergency call sequences repeating	1 – 5	<b>37</b>		1
Time of failure duration	0 – 9	<b>38</b>		1
Dial type tone/pulse	1 / 0	<b>41</b>		1
Character to prolong a call	* / #	<b>42</b>		1

LLW hanging up from phone		<b>43</b>		2
Service password		<b>44</b>		4
Confirmation character	2-6digits	<b>45</b>		6
Time waiting for confirmation	cx5 [sec]	<b>46</b>		1
Time without ringing tone (call?)	1 – 0	<b>47</b>		1
Code for relay switching from phone		<b>48</b>		2
Time of relay closing		<b>49</b>		2
Number of rings before picks up		<b>51</b>		1
Max call duration	[min]	<b>52</b>		1
Time of button holding	[sec]	<b>53</b>		1
Hanging up time when is redial	[sec]	<b>54</b>		1
Time before starts dialling	[sec]	<b>55</b>		1
Service call time	[dny]	<b>56</b>		1
Tone duration time	(n+5)x10	<b>57</b>	ms	1
Space duration between tones	(n+5)x10	<b>58</b>	ms	1
Flash	nx100	<b>59</b>	ms	1
Pause / internumeral space	nx100	<b>50</b>	ms	1

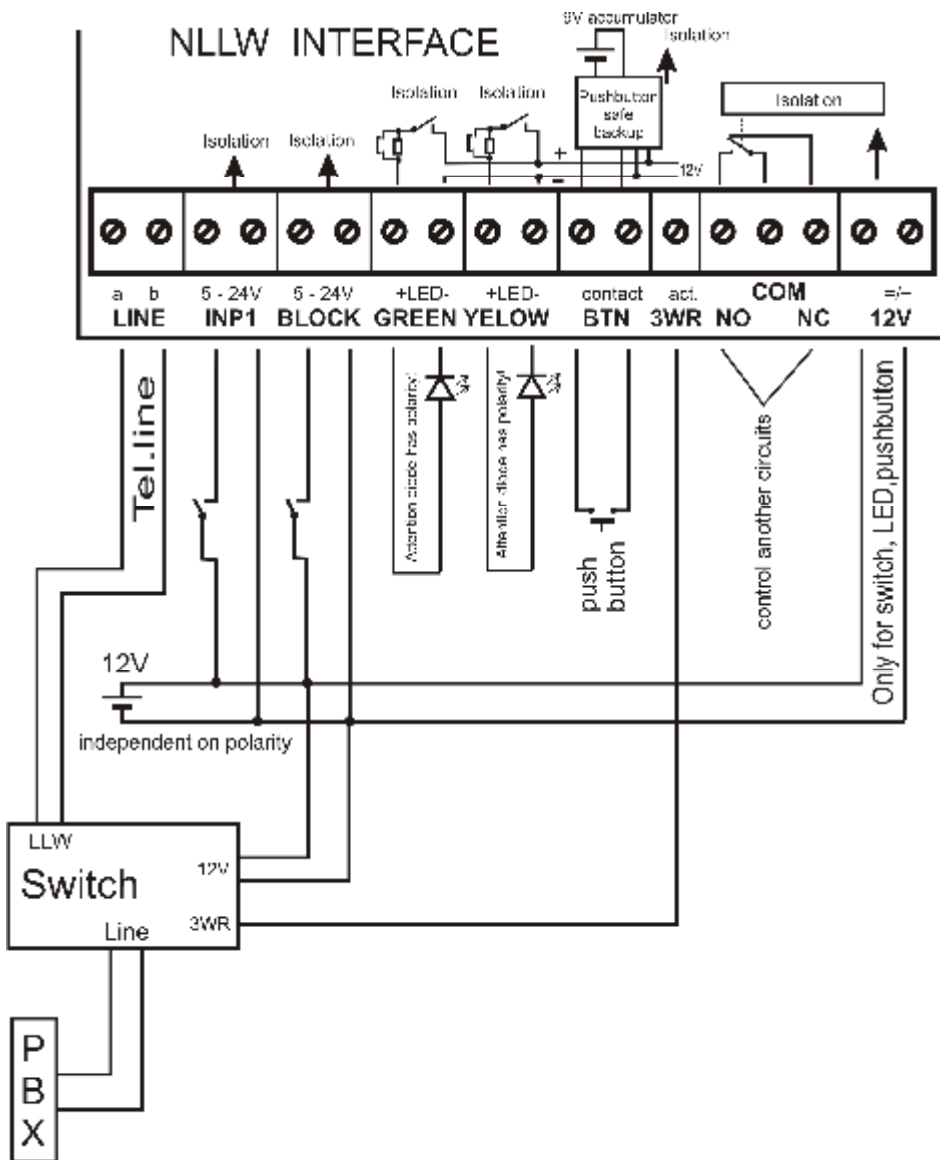

Picture 11: Example of connection with LED, blocking and failure is activated by voltage connection, machine room communication

Produced by:

Distributed by:

Date of sales:

**ALPHA**  
**Tech**

© JR 2005-9 verze V5.6 X/09